

ZANUSSI

FREEZER CONGELADOR ZEC 40

INSTRUCTION BOOKLET

MANUAL DE INSTRUÇÕES

CONTENTS

Warnings page	3
Conservation page	4
Installation page	5
Positioning page	5
Before using page	5
The electrical connections page	6
Location page	7
Door reversibility page	7
Fitting a decorative door panel page	8
Your appliance. page	10
Operation page	11
The controls page	11
Frozen food storage page	11
Ice making page	12
Thawing page	12
Freezing fresh food page	12
Helpful hints when buying food page	12
Defrosting page	13
Starting page	13
Normal sound page	13
Health and safety guidelines page	14
Maintenance and cleaning page	15
Internal cleaning page	15
When the appliance is not in use page	15
What happens if something goes wrong? page	16
Guarantee conditions. page	17

TECHNICAL SPECIFICATIONS

POWER SUPPLY VOLTAGE AND FREQUENCY	220-240 V / 50 Hz
TOTAL POWER ABSORBED	120 W
AVERAGE DAILY UNITS ELECTRICITY*	1.30 kWh
GROSS CAPACITY	120 l
NET CAPACITY	101 l
STAR RATING	

* This figure is based on standard test results in accordance with European Standard EN153. Actual consumption will depend on how the appliance is used and where it is located.

WARNINGS

IT IS MOST IMPORTANT THAT THIS INSTRUCTION BOOK SHOULD BE RETAINED WITH THE APPLIANCE FOR FUTURE REFERENCE. SHOULD THE APPLIANCE BE SOLD OR TRANSFERRED TO ANOTHER OWNER, OR SHOULD YOU MOVE HOUSE AND LEAVE THE APPLIANCE, ALWAYS ENSURE THAT THE BOOK IS SUPPLIED WITH THE APPLIANCE IN ORDER THAT THE NEW OWNER CAN GET TO KNOW THE FUNCTIONING OF THE APPLIANCE AND THE RELEVANT WARNINGS.

THESE WARNINGS ARE PROVIDED IN THE INTEREST OF SAFETY. YOU MUST READ THEM CAREFULLY BEFORE INSTALLING OR USING THE APPLIANCE.

- “ This appliance is designed to be operated by adults. Children should not be allowed to tamper with the controls or play with the product.
- “ Any electrical work required to install this appliance should be carried out by a qualified electrician or competent person.
- “ This product should be serviced by an authorised ZANUSSI Service Force Centre, and only genuine spare parts should be used.
- “ It is dangerous to alter the specifications or modify this product in any way.
- “ Care must be taken to ensure that the appliance does not stand on the electrical supply cable.
- “ ZANUSSI domestic refrigerators, freezers and fridge/freezers are designed to be used specifically for the storage of edible foodstuffs only.
- “ There are working parts in this product which heat up. Always ensure that there is adequate ventilation as a failure to do this will result in possible food loss. See installation instructions.
- “ Parts which heat up should not be exposed. Wherever possible, the back of the appliance should be close to a wall but leaving the required distance for ventilation as stated in the installation instructions.
- “ Before defrosting, cleaning or maintenance work is carried out, be sure to switch off the appliance and unplug it.
- “ Frozen food must NOT be re-frozen once it has thawed out.
- “ Do not place carbonated or fizzy drinks in the freezer as it creates pressure on the container, which may cause it to explode, resulting in damage to the appliance.
- “ The cooling plate or refrigerated freezer shelves in this appliance contain channels through which the refrigerant passes. If these are punctured this would cause substantial damage to the appliance and result in food loss. DO NOT USE SHARP INSTRUMENTS to scrape off frost or ice. Under NO circumstances should solid ice be forced off the lining or shelves. Solid ice should be allowed to thaw, when defrosting the appliance. See Defrost instructions.
- “ The appliance should be left for 2 hours after installation before it is turned on in order to allow the refrigerant to settle.
- “ This appliance is heavy. Care should be taken when moving it.
- “ Do not remove items from the freezer if your hands are damp/wet, as this could cause skin abrasions or “frost/freezer burns”.
- “ Ice lollies can cause “frost/freezer burns” if consumed straight from the freezer.
- “ Manufacturers’ storage recommendations should be strictly adhered to. Refer to relevant instructions.
- “ Under no circumstances should you attempt to repair the appliance yourself. Repairs carried out by inexperienced persons may cause injury or serious malfunctioning. Refer to your local ZANUSSI Service Force Centre and always insist on genuine spare parts.

CONSERVATION

In the interests of the Environment:

When disposing of your old fridge, freezer or fridge/freezer.

Help to keep your country tidy – use authorised disposal sites for your old appliances.

For maximum efficiency:

Make sure that the appliance is cleaned properly.

Make sure that the door is closed properly.

Do not position the appliance near to sources of heat.

Do not over-fill your appliance, air **MUST** be allowed to circulate.

INSTALLATION

Warning

IF YOU ARE DISCARDING AN OLD APPLIANCE THAT HAS A LOCK OR CATCH ON THE DOOR, YOU MUST ENSURE THAT IT IS MADE UNUSABLE TO PREVENT YOUNG CHILDREN BEING TRAPPED INSIDE.

Positioning

This appliance is designed to operate in ambient temperatures between 16°C (60°F) and 32°C (90°F). It should be located in a dry atmosphere, out of direct sunlight and away from extreme temperature e.g. not next to a cooker or other sources of direct heat, or in a very cold room e.g. an outhouse, where the temperatures may fall below 16°C (60°F). If these temperatures are exceeded i.e. colder or warmer, then the appliance may not operate correctly.

For building-in and door reversibility, if necessary, refer to the relevant instructions in the following pages.

Before using

Remove all securing tapes. Wash inside the appliance with lukewarm water and bicarbonate of soda (5 ml to 0.5 litre of water). Do not use soap or detergent as the smell may linger. Dry thoroughly.

The electrical connections

WARNING: THIS APPLIANCE MUST BE EARTHED.

The manufacturer declines any liability should this safety measure not be observed.

If the plug that is fitted to your appliance is not suitable for your socket outlet, it must be cut off and the appropriate plug fitted.

Remove the fuse from the cut off plug.
The cut off plug should then be disposed of to prevent the hazard of shocks in case it should be plugged into a 13amp socket in another part of your home.

Important

The wires in the mains lead are coloured in accordance with the following code:

Green and Yellow	- Earth
Blue	- Neutral
Brown	- Live

If you fit your own plug, the colours of the wires in the mains lead of your appliance may not correspond with the markings identifying the terminals in your plug, proceed as follows:

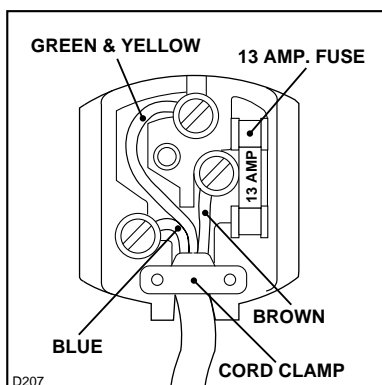

Fig. 1

Connect the Green and Yellow (earth) wire to the terminal in the plug which is marked with the letter «E» or the earth symbol \oplus , or coloured green and yellow.

Connect the blue (neutral) wire to the terminal in the plug which is marked with the letter «N» or coloured black.

Connect the brown (live) wire to the terminal in the plug which is marked with the letter «L» or coloured red.

The plug moulded onto the lead incorporates a fuse. For replacement, use a 13amp BSI362 fuse. Only ASTA or BSI approved fuses should be used.

The plug must not be used if the fuse cover/carrier is lost. The cover/carrier is indicated by the coloured insert at the base of the plug.

A replacement cover/carrier must be obtained from your local Zanussi Service Force Centre whose address is listed in the Customer Care Booklet which accompanies your instruction manual.

This appliance complies with the E.E.C. Directive No. 87/308 of 2.6.87 relative to radio interference suppression.

CE This appliance complies with the following E.E.C. Directives:

- 73/23 EEC of 19.2.73 (Low Voltage Directive) and subsequent modifications;
- 89/336 EEC of 3.5.89 (Electromagnetic Compatibility Directive) and subsequent modifications.

Please ensure that when the appliance is installed it is easily accessible for the engineer in the event of a breakdown.

Location

This appliance is designed to be built-in to a space having the dimensions given in Fig. 2.

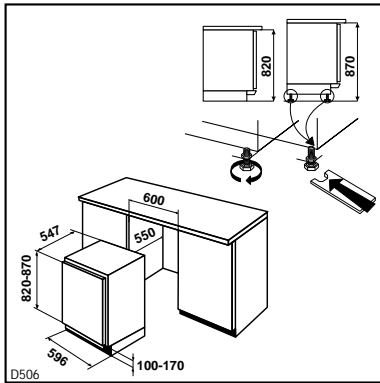

Fig. 2

The height of the appliance can be altered if required by means of adjustable feet situated at its base (Fig. 3).

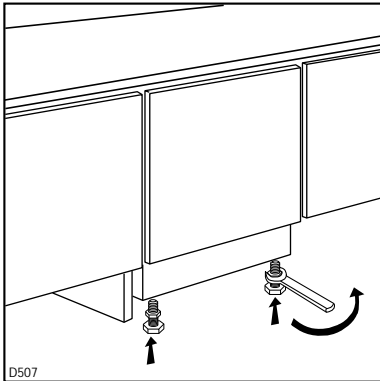

Fig. 3

Door reversibility

Remove the two screws which fix the upper hinge to the door.

Carefully lean the appliance on its back and remove the plastic insert (Fig. 4).

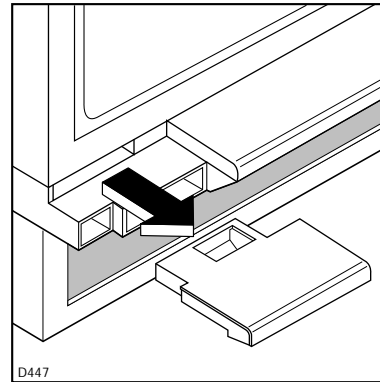

Fig. 4

Remove the two screws which fix the lower hinge to the door.

Remove the four screws which fix the lower hinge to the base of the appliance and remove the hinge itself; be very careful to recover all the screws.

Remove the four screws that fix the upper hinge to the appliance and remove the hinge itself.

Take the hinge removed from the upper part of the appliance on the opposite side (see Fig. 5), and, using the screws removed from the lower part, fix it to the base of the appliance itself.

Remove and refit the other hinge on the upper part of the appliance on the opposite side.

Fix the two front screws into the upper and lower hinges (Fig. 5).

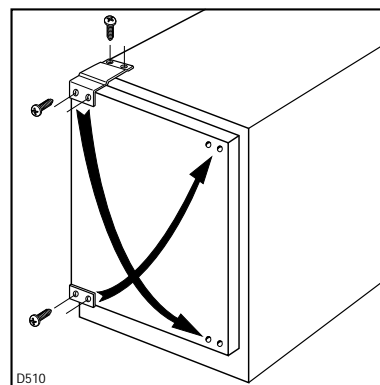

Fig. 5

Finally, check the alignment of the door and make sure it closes properly.

After having reversed the opening direction of the door, discard the original plastic insert removed and fit the insert supplied with the appliance on the opposite side.

Fitting a decorative door panel

Important: The components needed to fit the decorative panel have been pre-fitted on the appliance. The brackets are secured to the panel by means of the 7 $\text{Ø } 3.5 \times 13$ screws supplied.

Before starting to fit the panel, remove the large top bracket by unscrewing the screws and adjusting pins pre-fitted on the appliance door. The small bottom bracket need not be removed.

Place the appliance in the position where it is to be built in (Fig. 6).

The appliance is fitted with adjustable feet; screw the front and rear feet in or out to adjust the height of the appliance to that of the recess.

Keeping the appliance central in the recess, slide it in until its back touches the wall.

With a tape measure (or similar instrument), measure distance (A) between the top edge of the door and the top edge of the decorative panel, placing it next to the recess.

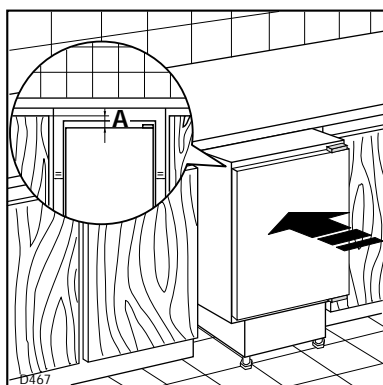

Fig. 6

Lay the panel face down (Fig. 7). Position the top bracket on the panel, making sure that there is an equal distance between it and the sides and that its distance from the top edge is equal to distance (A) less 1 cm.

Secure the bracket with the screws supplied. Take care not to damage the front face of the panel whilst working.

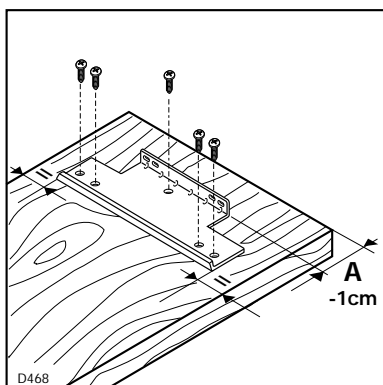

Fig. 7

Insert the adjusting pins (B-Fig. 8) into their locations in the door and screw them in.

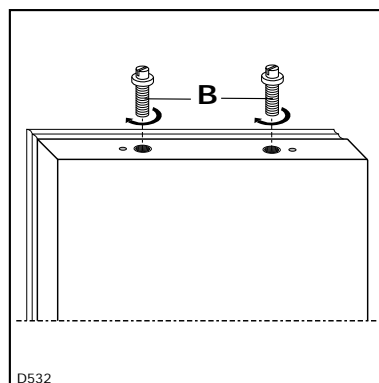

Fig. 8

Hook the decorative panel onto the top part of the door, inserting the pins (B) (on the door) into the elongated holes (1) (in the top bracket fitted to the panel) (Fig. 9).

Insert the securing screws (C) through elongated holes (2) and fix the panel without tightening the screws (Fig. 9).

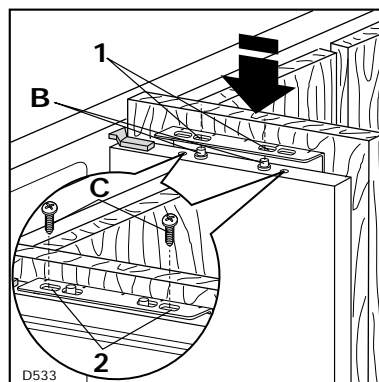

Fig. 9

Once the top of the panel has been correctly positioned, fix it through the holes in the bottom bracket, without tightening the screws (Fig. 10).

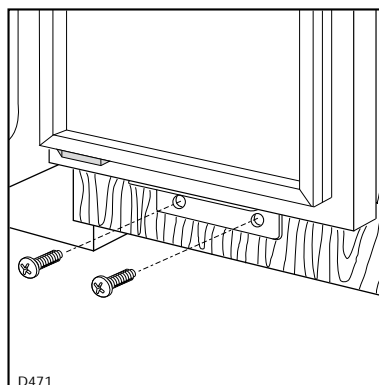

Fig. 10

Check the position again by slackening the screws and pins then, once the best position has been obtained, fully tighten all the fixings. Cover the visible part of the top bracket on the panel with plastic cover (D), inserting it in the locations provided in the bracket.

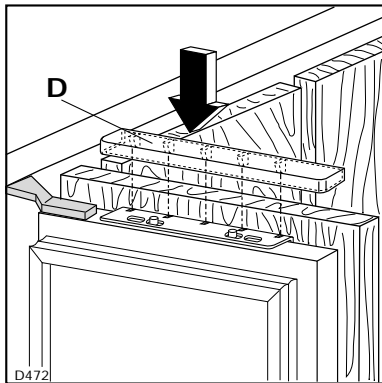

Fig. 11

Once the door has been correctly aligned, tighten the holding nuts on the fixing brackets and attach the appliance to the adjacent units and the bottom of the work surface (Fig. 12).

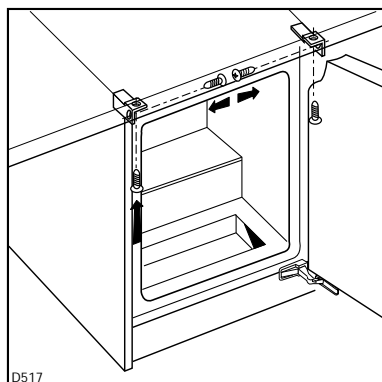

Fig. 12

If the appliance has been fitted into a space 820 mm high and the maximum height of the base plate is 100 mm, fit the front cover plate by pushing the two vertical lugs into the rectangular holes on the bottom side of the ventilation duct until they click. The plate can be adjusted backwards or forwards in the holes (Fig. 13).

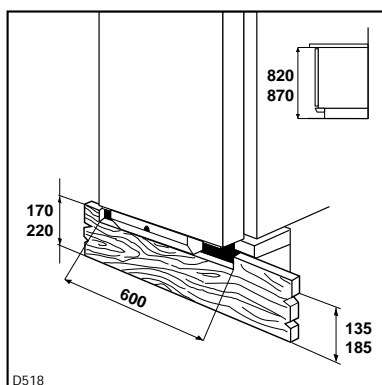

Fig. 13

If the base plate is between 100 and 135 mm high, cut it as shown in Fig. 15 and mount as described above.

If the base plate is between 135 and 170 mm high, cut it as shown in Fig. 13.

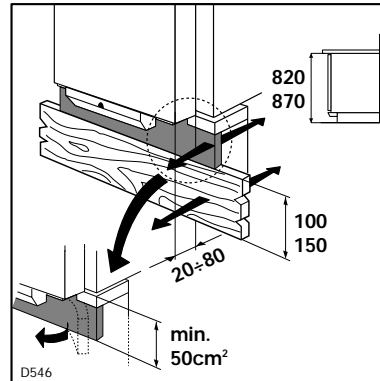

Fig. 14

If the appliance has been fitted into a space 870 mm high and the maximum height of the base plate is 150 mm, fit the front cover plate as described in Fig. 14.

If the base plate is between 150 and 185 mm high, cut it as shown in Fig. 15.

If the base plate is between 185 and 220 mm high, cut it as shown in Fig. 13.

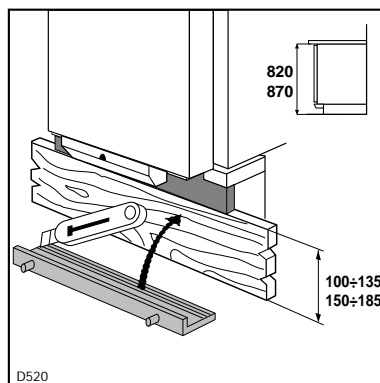
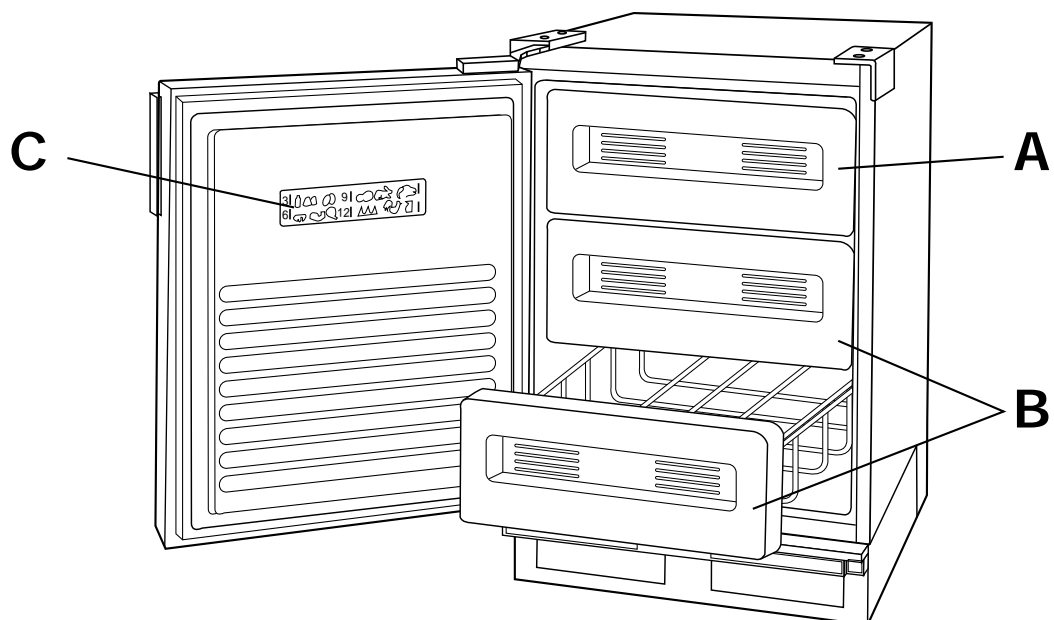

Fig. 15

YOUR APPLIANCE



A - Freezing fresh foods

B - Frozen food storage

C - Freezer calendar

OPERATION

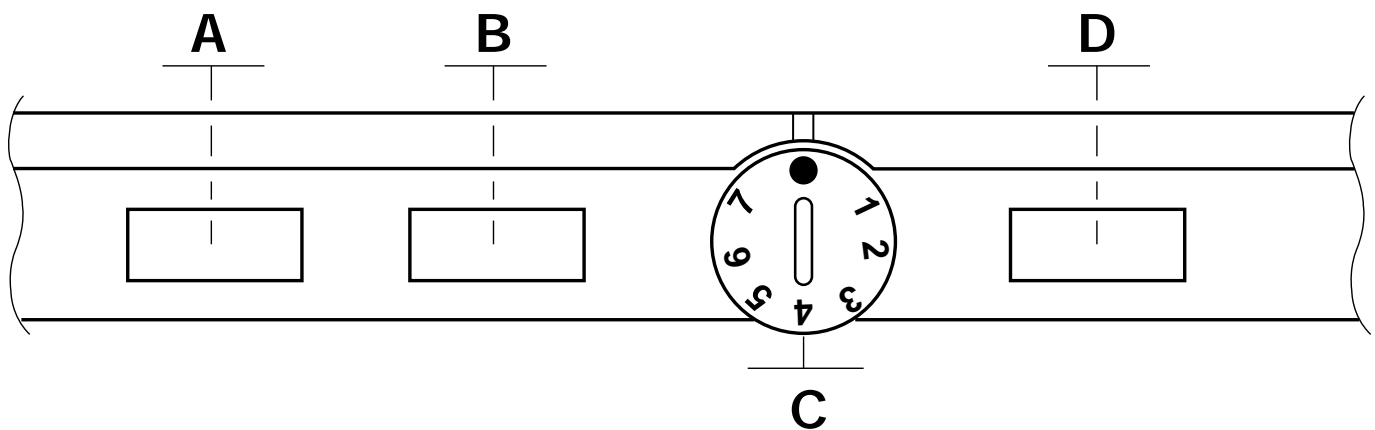

Fig. 16

This 4 (❄❄❄❄) freezer is suitable for the storage of commercially frozen food marked with 2-4 stars. The normal operating temperature of -18°C is suitable for long term storage of frozen food. Pre-packaged, commercially frozen food is normally suitable for storage of up to 3 months, unless otherwise stated by the manufacturer. This appliance is also suitable for freezing fresh food.

The top basket should be used to freeze fresh food.

The controls (See Fig. 16)

The control panel is situated at the base of the appliance, and can be seen under the door.

A. Fast freeze button

When you place fresh food in the appliance, you press the fast freeze button; the length of time you need to leave the appliance on fast freeze depends on the weight of food.

B. Red temperature alarm indicator light

The red temperature alarm light will come on as soon as the freezer is plugged in, or when it has been filled with fresh food until it reaches the correct temperature. This light will come on when the temperature rises above normal in the cabinet.

C. Thermostat control

Turn the thermostat control knob clockwise to the required setting, which is 3-4.

D. Mains On button

The green mains on button is illuminated continuously, to show that the appliance is on.

Frozen food storage

Your appliance has the following frozen food net storage volume: 92 litres weight of stored food 29.4 kg.

Operate the fast freeze switch BEFORE placing fresh food to be frozen in the freezer.

Place fresh food to be frozen in the top basket; food is completely frozen 24 hours later.

When the food is completely frozen it can be transferred to one of the other 2 baskets. If a very small quantity of fresh food is to be frozen, it is NOT necessary to adjust the thermostat control in advance. Always ensure that air can circulate around the food to be frozen; this will help it to freeze quicker.

Do not allow fresh food which is to be frozen, touch food which is already frozen.

During the freezing process, please make sure that the door remains closed.

Important

If the temperature of frozen food rises because of:

- Non compliance with manufacturer's recommendations,
- Electric power failure,
- Defrosting,

then recommended storage life may be reduced and storage times may not apply.

Frozen food which is allowed to thaw accidentally should either be used immediately or thrown away.

Alternatively if the food is uncooked and has not been completely defrosted it can be cooked and then refrozen.

Ice making

Fill the ice tray with fresh drinking water to just below the top of each cube compartment and place in the top compartment where it will freeze quickly.

To release the ice cubes, twist the ice tray along its length and the cubes will come out. They can then be stored in a container to use at a later date.

Thawing

Thaw frozen food in the fridge or at room temperature, depending on the time available.

Some small items may be cooked from frozen, but please allow extra time for cooking.

Any frozen food which has defrosted accidentally should either be consumed as soon as possible or thrown away. If the thawed food is uncooked and has not been completely defrosted, it can be cooked and refrozen.

DEFROSTED FOOD MUST NEVER BE REFROZEN

Important points to remember...

DO...

- * Label the food stored in your freezer, and use in date order, ensuring that you are consuming food at its best.
- * Leave the door ajar when the freezer is not in use.

DO NOT...

- * Use a SHARP INSTRUMENT to remove ice and frost.

Note

1. Do not place sealed containers of carbonated liquids such as fizzy drinks into the freezer as it creates pressure on the container which may cause it to explode, resulting in damage to the freezer.
2. Water ices and ice lollies should not be consumed immediately after removal from the freezer as it may result in low temperature skin abrasions.

Freezing fresh food

The maximum quantity of food you can freeze in 24 hours is 10 kg. Run for 3 - 4 hours before loading with food. After 24 hours the food will be fully frozen.

Note

Aim to check dates on packets and rotate food regularly. Although storage longer than recommended is not harmful, flavours and textures begin to deteriorate.

Warning

Do NOT remove items from the freezer if your hands are damp/wet, as this could cause skin abrasions or "frost/freezer" burns.

Helpful hints when buying food

1. Always ensure that fresh food you purchase is of a good quality and in prime condition.
2. Shop at a reliable source and buy the "freshest" looking packages; avoid shopworn labels or produce covered in dust.
3. Avoid buying frozen food if you cannot store it straight away. The use of insulated containers is advisable. When you arrive home place the frozen food in the freezer immediately.

Defrosting

The frost should be occasionally removed using either a stiff bristle brush or a plastic scraper.

Heavy frosting (about 1/4" thick) will reduce the freezer's efficiency and complete defrosting should be carried out at this stage.

It is preferable to defrost the freezer when there is little or no food in it. The procedure is as follows:

Any remaining frozen food should be placed in newspaper, wrapped in blankets and stored in a cardboard box which you should then put in a cool, dry place, or put the food in another freezer.

Then turn the mains on indicator light switch OFF.

Defrosting can be speeded up by putting bowls of hot (NOT boiling) water on the shelves of the freezer.

When the ice has melted, remove the water collected in the base of the freezer.

After defrosting, clean and dry the interior of the freezer, plug the appliance in and turn on the mains on indicator light switch and the fast freeze switch.

Replace the frozen food and check that the thermostat is at the correct setting.

* Please note:

If the temperature of the frozen food is allowed to rise during defrosting, its storage life may be shortened.

Starting

Before the appliance is installed into the recess plug into the mains and switch on. Check that the mains on light comes on and the control dial is correctly set. (See "The controls"). You will hear the compressor start up.

Normal sound

It is quite normal for refrigerators and freezers to make a certain amount of noise. The noise level will vary according to where the cabinet is positioned.

Noise and vibration can arise if the cabinet is unsteady or is close up to some other fitment such as a sink unit or dishwasher.

Refrigeration system. A faint gurgling or bubbling sound can be heard when the refrigerant is pumped through the coils of tubing at the rear or cooling system.

Compressor. When the refrigerant is pumped round, a whirring or pulsating noise may be heard from the compressor.

Thermostat. The compressor is started and stopped by the thermostat. A click can be heard when the thermostat cuts in and out.

Important notice

In line with our continuing policy of research and development we reserve the right to alter models and specifications without prior notice.

This instruction booklet is accurate at the date of printing but will be superseded and should be disregarded if specifications or appearance are changed.

HEALTH AND SAFETY GUIDELINES

Because of consumer demand, preservatives have been removed from many pre-prepared foods. This together with the changes in shopping habits to a once-a-week shop, mean that safe handling and storage of food is even more important than ever.

The following tips should help you to ensure that the food in your home is in as perfect condition as possible.

- “ Keep the time between buying chilled food and placing it in your freezer as short as possible. Tests showed that the temperature of 1 litre of orange juice rose to 22°C in an hour between the supermarket and home. It then took 11 hours to get down to 7°C in the refrigerator.
- “ Keep the freezer door closed as much as possible. Remember that warm air is flowing in as you are deciding what to have for tea!
- “ Do not push food together too much, try to allow air circulate around each item.
- “ Cool cooked food as quickly as possible but do NOT place in the freezer until cool. (Leave food in a place as cool as possible in order that it can then be placed in the freezer as soon as possible).
- “ Do not store food uncovered.
- “ The best way to defrost food is to put it in the refrigerator to thaw slowly.
- “ Ensure that food placed in the freezer is dated and labelled and used in date order to ensure that food is consumed at its best.
- “ It is important that food is used before its “best before” date.
- “ Always wash your hands with soapy water and dry them with a clean towel before handling food.
- “ Keep work surfaces clean and avoid cross contamination by not using the same work surface or knife, without washing them thoroughly in between.
- “ Use kitchen roll wherever possible for cleaning up food. If you use a dishcloth, be sure to boil it frequently.

MAINTENANCE AND CLEANING

Before any maintenance or cleaning work is carried out, DISCONNECT the appliance from the ELECTRICITY supply.

Internal cleaning

Clean the inside and accessories with warm water and bicarbonate of soda (5ml to 0.5 litre of water). Rinse and dry thoroughly.

NEVER USE DETERGENTS, ABRASIVE POWDERS, HIGHLY PERFUMED CLEANING PRODUCTS OR WAX POLISHES, TO CLEAN THE INTERIOR AS THESE WILL DAMAGE THE SURFACE AND LEAVE A STRONG SMELL.

When the appliance is not in use

When the appliance is not in use for long periods, disconnect from the electricity supply, empty all foods and clean the appliance, leaving the door ajar to prevent unpleasant smells.

WHAT HAPPENS IF SOMETHING GOES WRONG?

Before contacting your local Zanussi Service Force Centre, check the following points:

The appliance does not work...

Check that:

- “ There is power at the socket.
- “ Ensure that there is not a power cut by checking the household lights.
- “ The fuse has not blown.
- “ The air circulation passages are not covered.

Vibration or abnormal noises...

- “ You may hear faint gurgling or bubbling sounds when the refrigerant is pumped through the coils of tubing at the rear, to the cooling plate/evaporator or to the fixed freezer shelves. When the compressor is on, the refrigerant is being pumped round, and you will hear a whirring or pulsating noise from the compressor. A thermostat controls the compressor, and you will hear a faint “click” when the thermostat cuts in and out.

Other points to check...

Check that:

- “ Have you turned the thermostat to the correct setting?
- “ Has the door been left open causing the temperature to rise?
- “ Sometimes the freezer door will be difficult to open shortly after you have closed it. Don't worry this is due to pressure difference which will quickly equalise and allow the door to open normally.

If, after the above checks, there is still a fault, call your local Zanussi Service Force Centre, whose address can be found in the accompanying Customer Care Booklet, and can also be found in your local telephone directory under «Z».

In-guarantee customers should ensure that the above checks have been made as the engineer will make a charge if the fault is not a mechanical or electrical breakdown.

Please note that proof of purchase is required for any in-guarantee service calls.

Before contacting your local Zanussi Service Centre, make a note of the model and serial number. This information can be found on the rating plate situated inside the cabinet behind the bottom fridge/freezer drawer.

SERVICE DETAILS - ADHESIVE LABEL

When you return your guarantee card to Zanussi Ltd., you will receive an Appliance Guarantee and Maintenance Record Card together with an adhesive label. The label can be stuck to the machine or adjacent furniture.

PEACE OF MIND FOR TWENTYFOUR MONTHS

Zanussi standard guarantee conditions

This guarantee is in addition to your statutory and other legal rights which will not be excluded or in any way diminished by the return of this guarantee card.

We, Zanussi Ltd., undertake that if, within twentyfour months of the date of the purchase, this ZANUSSI appliance or any part thereof is proved to be defective by reason only of faulty workmanship or materials, we will, at our option, repair or replace the same **FREE OF ANY CHARGE** for labour, materials or carriage on condition that:

- “ The appliance has been correctly installed and used only on the electricity supply stated on the rating plate.
- “ The appliance has been used for normal domestic purposes only, and in accordance with the manufacturer’s operating and maintenance instructions.
- “ The appliance has not been serviced, maintained, repaired, taken apart or tampered with by any person not authorised by us.

All service work under this guarantee must be undertaken by a Zanussi Service Centre.

Home visits are made between **8.30am** and **5.30pm** Monday to Friday. Visits may be available outside these hours in which case a **premium** will be charged.

Any appliance or defective part replaced shall become our property.

Exclusions

This guarantee does not cover:

- “ Damage or calls resulting from transportation, improper use or neglect, the replacement of any light bulbs or removable parts of glass or plastic.
- “ Costs incurred for calls to put right machines improperly installed or calls to machines outside the United Kingdom.
- “ Appliances found to be in use within a commercial environment, plus those which are the subject of rental agreements.
- “ Products of Zanussi manufacture which are **NOT** marketed by Zanussi Ltd.
- “ EU Countries - The standard guarantee is applicable but is subject to the owner’s responsibility and cost to ensure the appliance meets the standards set by the country to which the product is taken. The Zanussi Company in the country concerned will be pleased to advise further. Sight of your purchase receipt will be required by them.

